

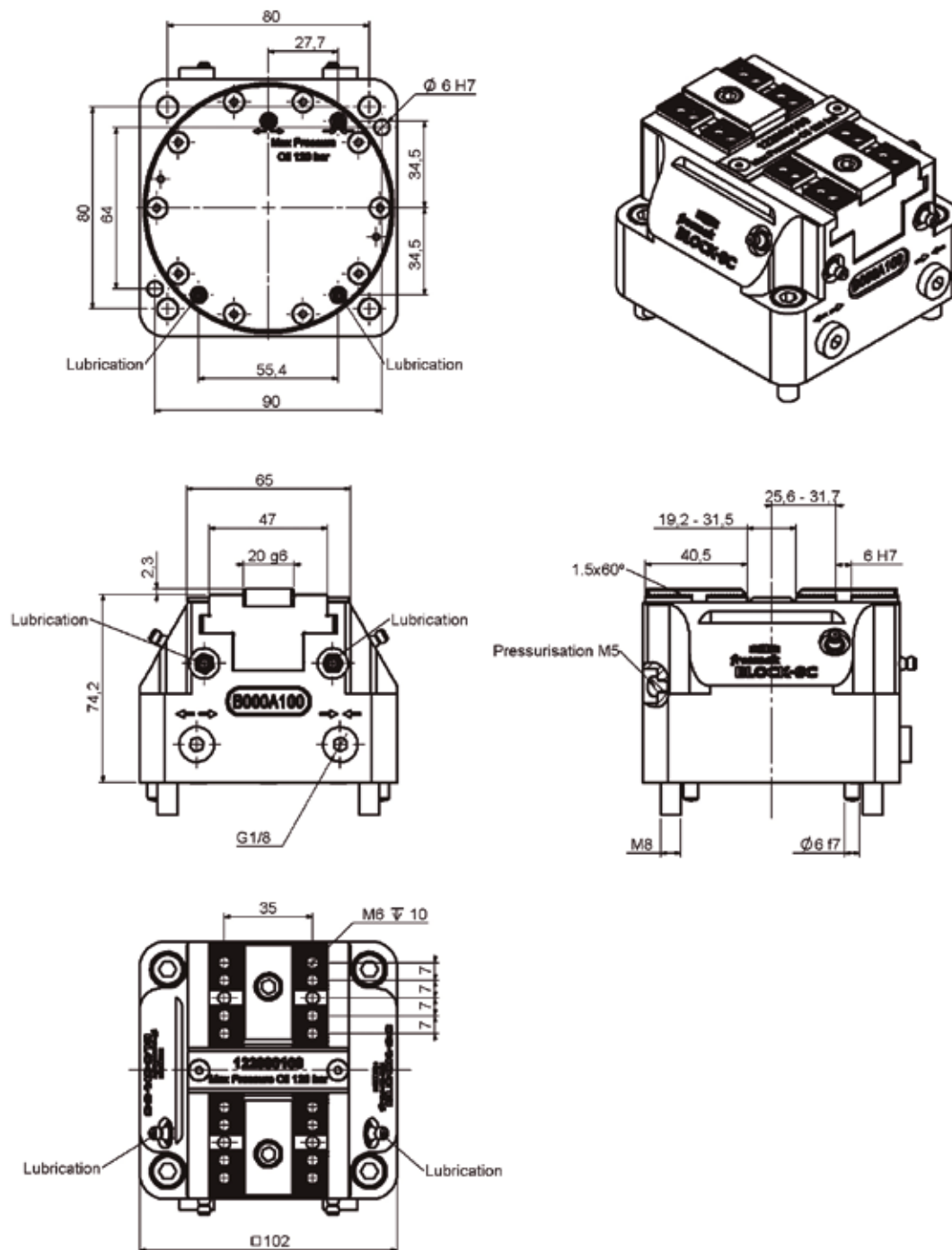

Tam.	Ref.	Fuerza de amarre kN	Presión Max. bar	Carrera x Boca mm	Repetibilidad mm	Max Altura mm	Consumo Aceite cm ³	Peso Kg
HIDRÁULICO 100	122 000 100	16	120	6	0,01	60	30	5

* La fuerza de amarre total del plato autocentrante BLOCK-SC es la suma aritmética de las fuerzas individuales de cada boca o garra.





Tam.	Ref.	Fuerza de amarre kN	Presión Max. bar	Carrera x Boca mm	Repetibilidad mm	Max Altura mm	Consumo Aceite cm ³	Peso Kg
HIDRÁULICO 160	122 000 160	40	120	8	0,02	60	90	14

* La fuerza de amarre total del plato autocentrante BLOCK-SC es la suma aritmética de las fuerzas individuales de cada boca o garra.

